



ART. 82.3R



ART. 82.7R.43



ART. 82.7R



ART. 82.6R



ART. 82.55



ART. 82.56.43



ART. 82.56



ART. 82.44



ART. 82.16L



ART. 82.19L.43



ART. 82.19L



ART. 82.18L



.Rs

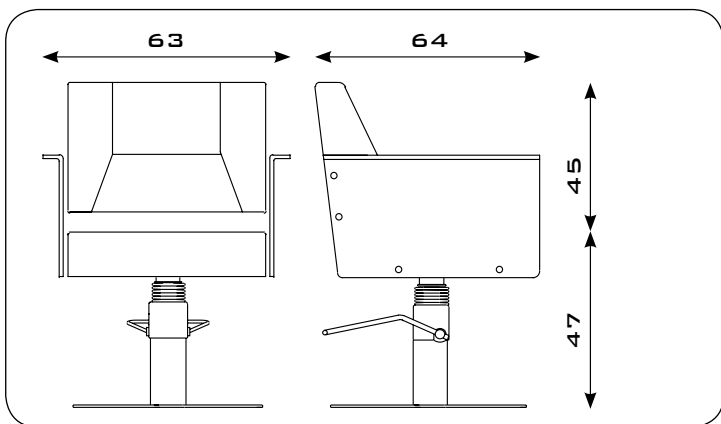

TEX



Grande è il contrasto di materiali che creano il design della poltrona Tex. Particolari sono la seduta e lo schienale in poliuretano espanso a densità variabile sagomato, che offre la massima comodità. I due braccioli sono in metacrilato fumè.

TEX



The design of the Tex chair is focused on its highly contrasting materials. It has a special seat and chair back in shaped expanded polyurethane of variable thickness, which offers maximum comfort. The two arms are in smoked methacrylate.

TEX



Le contraste des matériaux qui créent le design du fauteuil Tex est très marqué. L'assise et le dossier en polyuréthane expansé à densité variable profilé, procurent un confort optimal, et sont d'une grande originalité. Les accoudoirs sont en méthacrylate fumé.

TEX



Das Design des Stuhls Tex entsteht durch den großen Kontrast der verwendeten Materialien. Ein besonderes Kennzeichen sind Sitz und Rückenlehne aus geformtem Polyurethanschaum mit unterschiedlicher Dichte, die höchsten Sitzkomfort bieten. Die beiden Armlehnen bestehen aus rauchfarbenem Methacrylat.

TEX



Los materiales que crean el diseño del sillón Tex se caracterizan por su elevado contraste. La particular forma del asiento y el respaldo, de poliuretano expandido de densidad variable perfilado, ofrece la máxima comodidad. Los brazos son de metacrilato ahumado.

...DETAILS



TEX

ART. 82.56

