

KING

Superficie in metacrilato nero o bianco lucido.
Doppia cornice in alluminio cromato lucido.
Piano in fusione di alluminio verniciato nero o bianco.

KING

Surface in gloss black or white methacrylate.
Double aluminium frame with polished chrome finish.
Shelf in aluminium alloy with enamel finish in black or white.

KING

Surface en méthacrylate noir ou blanc brillant.
Double cadre en aluminium chromé brillant.
Tablette en fonte d'aluminium peint noir ou blanc.

KING

Oberfläche aus Methacrylat, glanzschwarz oder glanzweiß.
Doppelter Rahmen aus glanzverschrotem Aluminium.
Ablage aus schwarz oder weiß lackiertem Aluminiumguss.

KING

Superficie de metacrilato negro o blanco brillante.
Doble marco de aluminio cromado brillante.
Repisa de fusión de aluminio pintada de color negro o blanco.

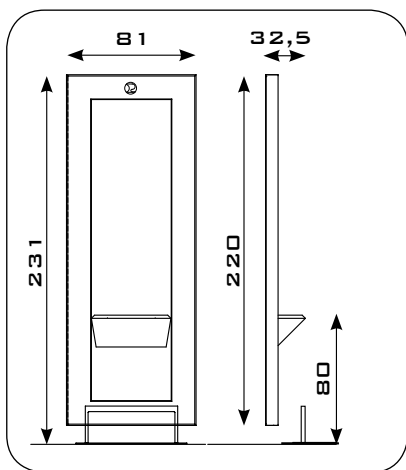
...DETAILS

ART. 39



ART. 57

KING

ART. 860



ART. 861

KING

Superficie in metacrilato nero o bianco lucido.
 Doppia cornice in alluminio cromato lucido
 Piano in fusione di alluminio cromato lucido
 Portaphon cromato.

KING

Surface in gloss black or white methacrylate.
 Double aluminium frame with polished chrome
 finish. Shelf in aluminium alloy with polished
 chrome finish.
 Hair dryer holder with chrome finish.

KING

Surface en méthacrylate noir ou blanc brillant.
 Double cadre en aluminium chromé brillant.
 Tablette en fonte d'aluminium, chromé, brillant.
 Porte-séchoir chromé.

KING

Oberfläche aus Methacrylat, glanzschwarz oder
 glanzweiß.
 Doppelter Rahmen aus glanzverschrotem
 Aluminium. Ablage aus glanzverschrotem
 Aluminiumguss. Verchromte Föhnablage.

KING

Superficie de metacrilato negro o blanco
 brillante. Doble marco de aluminio cromado
 brillante. Repisa de fusión de aluminio
 cromado brillante. Portasecador cromado.

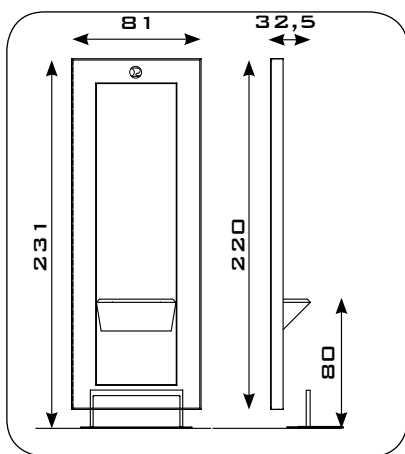
...DETAILS

ART. 39



ART. 57

KING

ART. 862



ART. 863